

A Syntactic Study of Conceptual Metaphors in Nollywood Movies

Eniayo Sobola & Olubunmi Agboola

*Department of English
University of Lagos, Akoka*

Abstract

*Syntax deals with the arrangement of grammatical elements in phrases, clauses and sentences. It does not only involve word ordering in a sentence but also investigates the relationship between the forms of words in a sentence (Dadzie, 2004). Conceptual metaphor is the expression of a concept in terms of another. Every aspect of language is structurally organised to achieve grammaticality, part of which is figurative language. This study is interested in the syntactic representation of structural patterns in the conceptual metaphors found in two Nollywood movies: *Aya wa ni* (Yoruba) and *He Goat* (English), and also the meaning mechanism involved in the interpretation of metaphorical structures. One of the two movies selected was produced in Yoruba and subtitled in English with Yoruba sociocultural and sociolinguistic settings while the second was produced in English with Igbo socio-cultural and sociolinguistic settings. Since the study is based on structural analysis of metaphorical expressions, Chomsky's (1993) minimalist program is used as the main analytical framework while Lakoff and Johnson's (1980) conceptual metaphor theory is used as supporting analytical tool for metaphorical interpretation of the text. This study argues that conceptual metaphor has structural patterns similar to literal language; its syntactic structure does not affect complexity of its interpretation; there are technicalities such as movement and merger operations in the structure of conceptual metaphor, and conceptual metaphor is interpreted through mapping of the sets of correspondences shared by the two conceptual domains in the metaphor.*

Introduction

Every aspect of language is structurally arranged. The arrangement determines whether the language is used grammatically or otherwise. The

structural arrangement of words into larger units of grammar called syntax determines the meaning of an expression to a large extent, in the sense that it shows the relationships among the words in a sentence (Dadzie, 2004). Structural classification of conceptual metaphor portrays linguistic features inherent in the metaphor. Structural metaphors do not only propel meaning mechanism in metaphorical understanding; they also give credence to syntactic study of conceptual metaphor. The interest of linguists who work on syntax is investigating the status and nature of grammatical elements in relation to their relationships in a syntactic structure. Syntactic study of rhetorical devices such as metaphor, simile, personification, metonymy and synecdoche makes research interesting as it shifts focus from normal language usage to figurative use of language.

Literature Review

A lot of scholarly works have been done on the study of metaphor such as Fromkin et al (2003) which explore metaphor as an essential part of semantics; Opeibi (2009) investigated metaphors as persuasive techniques in political discourse; Papagno (2001) examined metaphors and idioms in the language of patients with Alzheimer's disease; Bielen-Grajewska (2009) investigated the role of metaphor in the language of investment in banking; Cunningham-Parmeter (2011) studied immigration metaphors from legal a perspective as alien language; Pierson (2008) studied the relevance of educational metaphors for teaching English as a second language to adult learners. Among these scholars, none has conducted a study on the syntactic representation in conceptual metaphor using Chomsky's (1993) minimalist program as an analytical tool which makes this study different from earlier studies.

A few studies have been done in the application of minimalist program as a theoretical tool. Among these studies are Igbeneghu (2003) which explores determiner phrase in Etsako and Ademola-Adeoye (2012) which discusses raising in the minimalist program. None of these studies has attempted to investigate syntactic representation of metaphoric expressions, especially conceptual metaphor which is the point of study in this paper.

Conceptual Metaphor

Metaphor is a linguistic expression which shows a relationship between two contradicting words in a sentence. It uses one concept to designate another concept in order to create an implicit comparison. In this comparison the meaning of one concept in the expression is transferred to the other which is contradictory to it (Bailer-Jones, 2002). Conceptual metaphor is described as the understanding of one conceptual domain in terms of another. In conceptual metaphor, there are two conceptual domains – source domain and target domain (Lakoff, 1989, 1990; Lakoff and Johnson, 1980). There is a correspondence between the two conceptual domains through mapping. It is conceptual mapping that helps to bring out the features shared by the two concepts in a metaphorical structure to generate meaning. Structure is germane in construction of metaphorical expressions. Structural metaphors, as a classification of conceptual metaphor, imply that one concept is metaphorically structured in terms of another; thereby the source domain provides appropriate knowledge structure for the target domain (Lakoff and Johnson, 2003; Kövecses, 2010). Structural arrangement of conceptual metaphor aids its interpretation.

Nollywood Movies

Nollywood is an appellation which has become the identity of Nigerian film industry. The name given to the industry by Matt Steinglass in 2002 published in *New York Times* rebrands the mission that started with roving theatre group called “Alarinjo”, the Yoruba travelling theatre troupes, who staged their plays in different places in cities and villages visited by the group (Adesanya, 1997; Haynes and Okome, 1997, Haynes, 2005; Oni, 2008). Nigerian films have been used to tell Nigerian stories both in Nigerian languages and foreign languages in order to reach both local and foreign audience. Most of the films produced in Nigerian languages are subtitled in English to bridge the communication barrier with foreign audience. The films employ metaphors among other rhetorical devices to demonstrate Nigerian socio-cultural identity. The metaphors can be understood in the situational and cultural contexts, but their structural composition remains faithful to syntactic rules.

Theoretical Framework

The two theoretical tools used in this study are Chomsky's (1993) minimalist program and Lakoff and Johnson's (1980) conceptual metaphor theory

Minimalist Program

Minimalist Program (MP), which is the latest version of Generative Grammar propounded by Noam Chomsky (1993), is the major analytical tool employed in this study for analysing the data. It is an elaborate work of Chomsky which is aimed at minimizing the theoretical and descriptive apparatus for analysing language (Radford 2004:9). Minimalism, as it is often otherwise called, is not a theory but a program, which refers to a family of approaches that aims at reducing syntax or grammar to its absolute minimum (Hans Broekhuis and Ellen Woolford, 2010:1). Minimalism aims at making grammar as simple as possible, as much earlier works of syntax involve formulation of complex assumptions and hypotheses.

Minimalist Program adopts most of the principles of Generative Grammar with few changes. In other words, the same principles that guide the Generative Grammar still guide the Minimalist Program. For example, the language feature of recursivity and productivity are adopted in the Minimalist Program as well. Basically, there was an upgrade in the nomenclatures of word categories and their attendant syntactic representations on the tree diagrams. The tree diagrams in the Minimalist Program are quite different from the earlier versions of Generative Grammar. Also, new phrases were introduced into the program. Chomsky posits that human beings process language in bits and chunks via merger and movement operations.

According to Radford (2009: 478), syntactic representation otherwise called structural representation is a notation/device (typically, a tree diagram or labelled bracketing) used to represent the syntactic structure of an expression. In other words the way in which it is structured out of words and phrases. Syntactic representation also refers to the diagrammatic representation of the sentence structures. Tree diagrams are used to show the various levels of projections in a top down/ bottom up fashion. The

drawing of tree diagrams is a significant aspect in the Minimalist Programme.

In successfully analysing sentences in the Minimalist Program (i.e. representing the structures on the tree diagrams), it behoves of anyone who wants to embark on such syntactic journey to be equipped with the necessary tools that will aid his trip. The first important thing to know in syntactic representation is furnishing one's knowledge with the word classes and grammatical categories. Also, it is expedient to learn the Xbar Theory (which is the template for building phrases in the Minimalist Program) in order to be able to analyse any sentence. Metaphoric expressions are no exceptions in syntactic representation as their structures often follow normal word order.

There are some basic assumptions in the Minimalist Program that would guide our understanding of the sentence analyses in this article. These assumptions would provide a clearer picture when the metaphors are structurally represented on the tree diagrams.

- Derivation of sentences occurs in a bottom-up fashion and we will present how that is done using one of the metaphors as a model.
- Most functional categories often have special features.
- Sentences are formed through merger and movement operations.
- The moved item often leaves a trace of itself in the LF (Logical Form.)

It is important to note that syntactic representation is highly significant in the Minimalist program, as it often indicates where specific features in a structure are highlighted.

Conceptual Metaphor Theory

Conceptual metaphor theory was propounded by Lakoff and Johnson (1980) for the study of metaphor in everyday language. They believe that everyday language, thoughts and actions are filled with metaphors, and comprehension of metaphorical expressions is dependent on metaphorical correspondence that guides our mental representation of complex concepts (Mcglone, 1996). The theory portrays that one conceptual domain is understood in terms of another conceptual domain through mapping of the

concepts in the two domains. The domains are the source domain which is the conceptual domain from which metaphorical expression is drawn and the target domain which is the conceptual domain intended to be understood. Mapping of the two conceptual domains aids effective interpretation of metaphorical expressions (Kövecses, 2002).

Methodology

Media monitoring is used to collect the data for this study from electronic platform which is YouTube where the films are uploaded for public viewing. The films are selected in no particular order: they are chosen just as representation of the two popular types of Nollywood movies in Nigeria. Metaphors in each of the films are extracted while viewing them, and ten of them were selected, five from each film, for analysis. Metaphors in *Aya wa ni*, a film produced in Yoruba subtitled in English, are analysed first while metaphors in *He Goat*, a film produced in English with Igbo socio-cultural and sociolinguistic setting, are analysed next to show the structural patterns in the metaphors.

Analysis of Conceptual Metaphors in *Aya wa ni*

Data presentation

- You are a dog.
- I am a leopard.
- She is the goddess of money.
- You are the fig tree.
- Obedience is sacrifice.

Data Analysis

Conceptual Metaphor 1: You are a dog

‘You are a dog’ generates a conceptual metaphor ‘man is a dog’. In the metaphor, ‘dog’ is the source conceptual domain while ‘man’ is the target conceptual domain. Man is understood here in terms of dog. This metaphorical expression is derived from the source domain, ‘dog’. It implies that ‘man’ and ‘dog’ shared some attributes that make them comparable. The attributes can be explicated through conceptual mapping.

Target Domain

Source Domain

Man

Dog

Vigilant	←————→	Sensitive
Attack	←————→	Hunting
Limitation	←————→	Limitation
Safety	←————→	Protection
Hostile	←————→	Frighten

The mapping shows that man can be understood in terms of dog. The meaning of conceptual metaphor 'you are a dog' could be derived from the sets of correspondence in the two conceptual domains. Man can be vigilant while dog is highly sensitive to its environment. Man can attack each other while dog hunts other animals. Both man and dog have limitation in terms of their strength and ability. Man can keep something in his custody safe while dog protects its territory, and lastly, man can be hostile to stranger while dog frightens strangers by barking at them ferociously.

Syntactic Representation

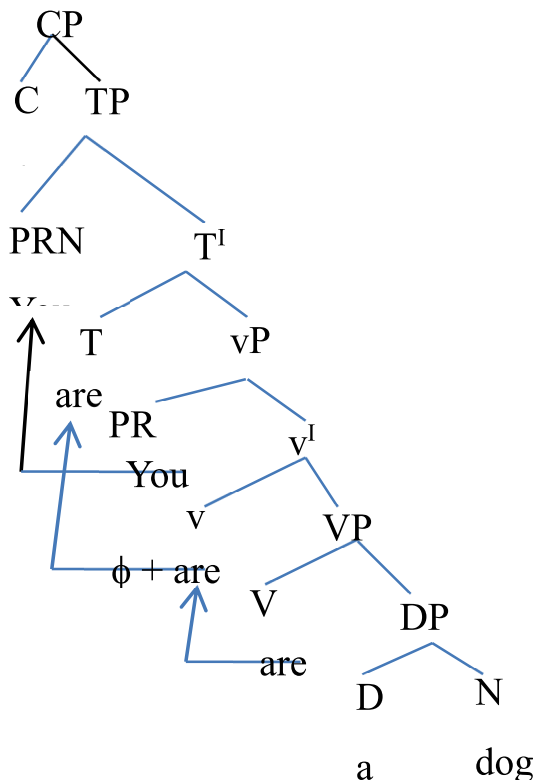

The conceptual metaphor ‘You are a dog’ can simply be regarded as a simple canonical (i.e. normal) sentence in the minimalist program.

In discussing the derivation of the above sentence, we can say that whoever is making the sentence “You are a dog” would, first of all, select the relevant words from his mental lexicon and begin to merge one category with another until the sentence is formed. The lexical array (i.e. the selection of lexical items out of which the sentence is going to be built) consists of the second person pronoun ‘You’, the second person singular simple present tense of be ‘are’, the indefinite article ‘a’ and the common noun ‘dog’. The category ‘D’ which is the article ‘a’ is selected and merged with the noun ‘dog’ to form the Determiner Phrase [a dog]. This DP merges with the auxiliary ‘are’ to form the VP [are a dog]. The VP is going to merge with the head, the light vP which has no phonetic content. The light vP which has a unique feature; that is, it is affixial in nature, triggers the auxiliary verb ‘are’ (which is the only verb in the sentence) to move from its in situ position to the light verb position. We simply place a strike through on ‘are’, indicating that it is first merged in V before it moves to attach to the light verb together with its complement VP it forms the light veebar (V^1).

The light v^1 merges with the specifier (the subject) which is a pronoun (that agrees in terms of person and number features) and together they form the light verb phrase(vP). When the light vP merges with another head which is a T, something is going to occur. T is a functional category, and it has an ¹EPP feature. When T(AUX) merges with the light vP, they form the Intermediate projection Tee bar (T^1); when the T^1 merges with the PRN that has moved from spec-vP, they form the maximal projection TP.

In order for our derivation to converge, we have to mark the sentence as declarative in force by merging our TP with a null complementizer (\emptyset).

¹ EPP is an abbreviation for Extended Projection Principle. It is a suggestion made by Chomsky (1982:10) that ‘a finite tense constituent T must be extended into a TP projection containing a subject.’

Finite T (Tense) carries person and number features, its (EPP) feature requires it to have a subject with matching person and/or number features.

Notably, the movement of the auxiliary 'are' from V to T is an exception to the standing rule in MP that finite T has a weak head in present-day English to attract the movement of main verbs to T in modern day English. Considering the fact that finite T has a strong AUX feature in the present-day English (Radford 2004), we would not be mistaken to represent our auxiliaries under T category via movement operation.

Conceptual Metaphor 2: I am a Leopard

'I am a leopard' generates a conceptual metaphor 'man is leopard'. The source conceptual domain is leopard while the target conceptual domain is man. Here, man is understood in terms of leopard because he has some attributes that make him comparable to leopard which can be demonstrated through mapping.

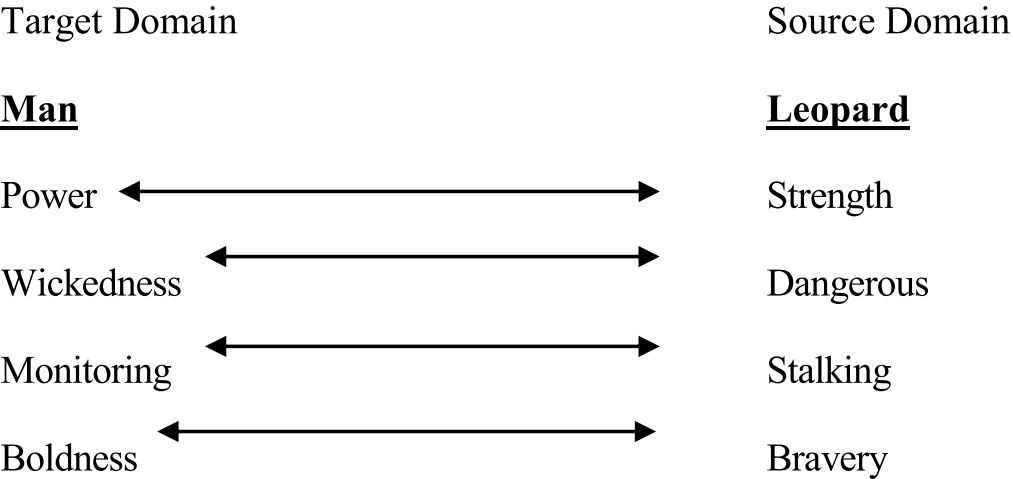

The mapping reveals that man can be understood in terms of leopard. The meaning of conceptual metaphor 'I am a leopard' can be generated from the sets of correspondence in the two conceptual domains. From that mapping, there are certain features shared by man and leopard. Man is powerful while leopard is full of strength. Man may have political, economic, spiritual or physical power. Leopard is muscularly built to

be strong. Wickedness of man can be compared to dangerous nature of leopard; therefore, man is wicked while leopard is dangerous. Man secretly monitors his target while leopard stalks to hunt its prey. Man displays fearlessness through boldness while leopard does the same through bravery.

Syntactic Representation

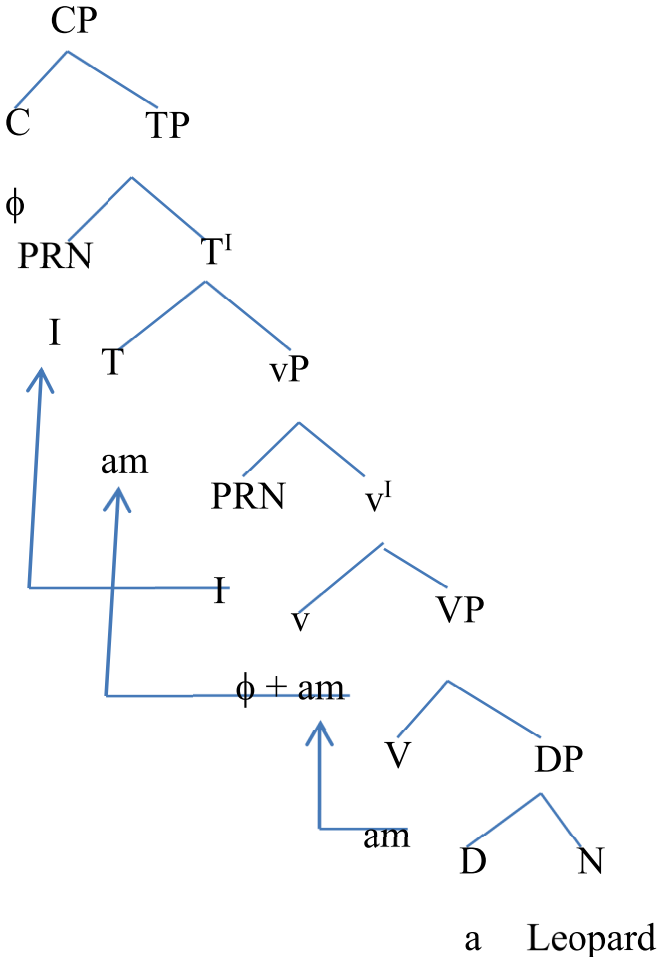

A careful look at the syntactic representation of conceptual metaphor 2 ‘I am a Leopard’ shows that it follows a similar structural pattern with the previous one analysed. This indicates that sentences with the same arrangement would most likely have a uniform derivation and tree diagram. The grammatical categories of the two metaphors are synonymous although the words selected are different.

PRN/ T/ D/ N

- You are a dog
- I am a Leopard

PRN stands for Pronoun,
T for Tense,
D for Determiner and
N for Noun.

Conceptual Metaphor 3: She is the goddess of money

‘She is the goddess of money’ generates a conceptual metaphor ‘woman is a goddess’. The source conceptual domain is goddess while the target conceptual domain is woman. Woman is understood in terms of goddess because there are some attributes shared by both of them. This is demonstrated through conceptual mapping.

Target Domain		Source Domain
<u>Woman</u>		<u>Goddess</u>
Beauty	←————→	Power
Care	←————→	Protection
Influence	←————→	Influence
Love	←————→	Worship

The mapping demonstrates how woman can be understood in terms of goddess. Woman’s beauty may be compared to power of goddess. As goddess controls humans through her power, woman can control desire of men through her beauty. Goddess is protective while woman cares about her people. Goddess has influence in different capacities – spiritual, natural, supernatural – over human; woman also has influence of attraction either through beauty or kindness or caring. Goddess is worshipped while woman is loved. The full metaphorical expression

portrays that the woman is influential like the goddess which has supernatural control over money.

Syntactic Representation

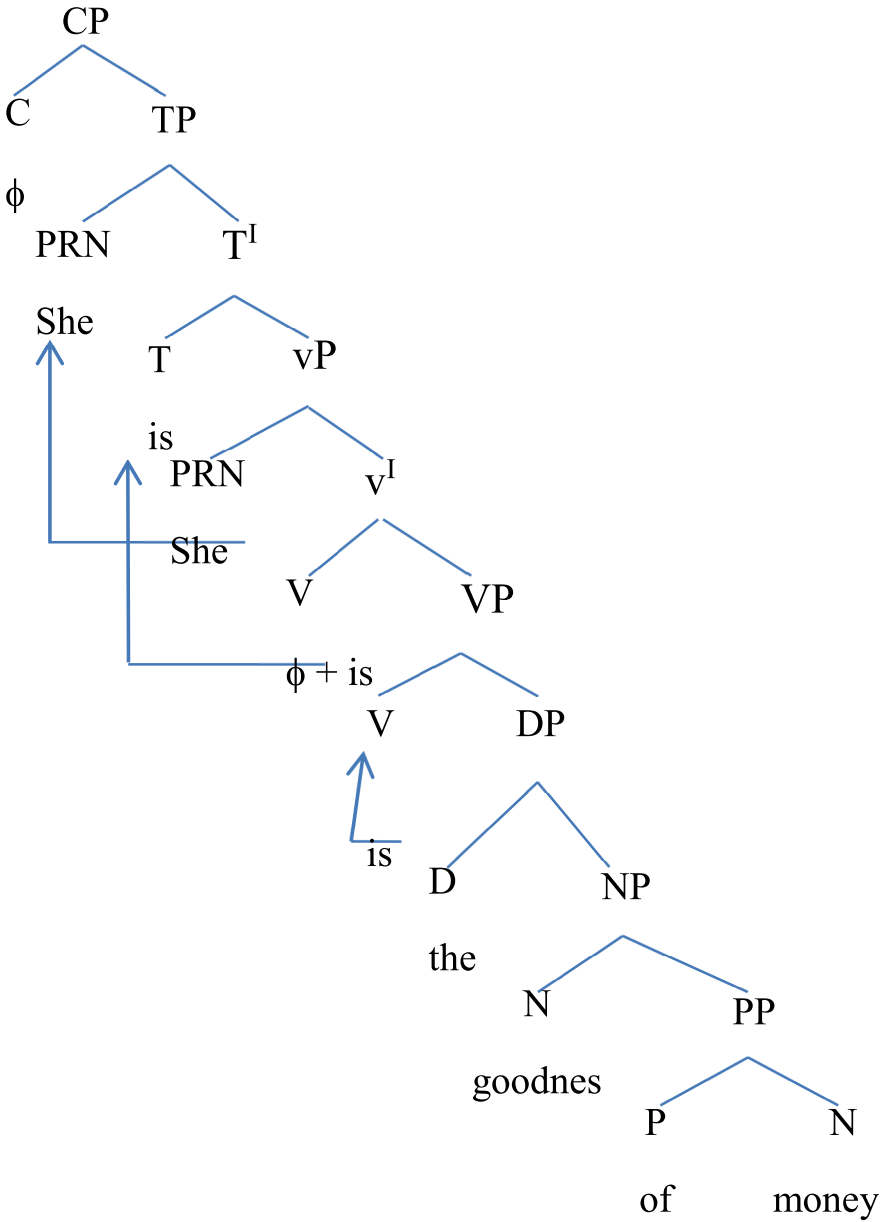

The above conceptual metaphor is a bit different from the previous ones as there is an introduction of a prepositional phrase within the noun phrase ‘the goddess of money’. It is also important to state the reason for merging the subject within the Spec vP (specifier position of the light verb phrase). The idea emanates from the VP-Internal Subject Hypothesis (VPISH) which has widely been adopted since the mid-1980s. The hypothesis states that subjects originate internally within vP (light verb phrase).

Conceptual Metaphor 4: You are the fig tree

‘You are the fig tree’ generates a conceptual metaphor ‘woman is fig tree’. The source conceptual domain is fig tree while the target conceptual domain is woman. Here, woman is understood in terms of fig tree as a result of some features they share. This is displayed through conceptual mapping.

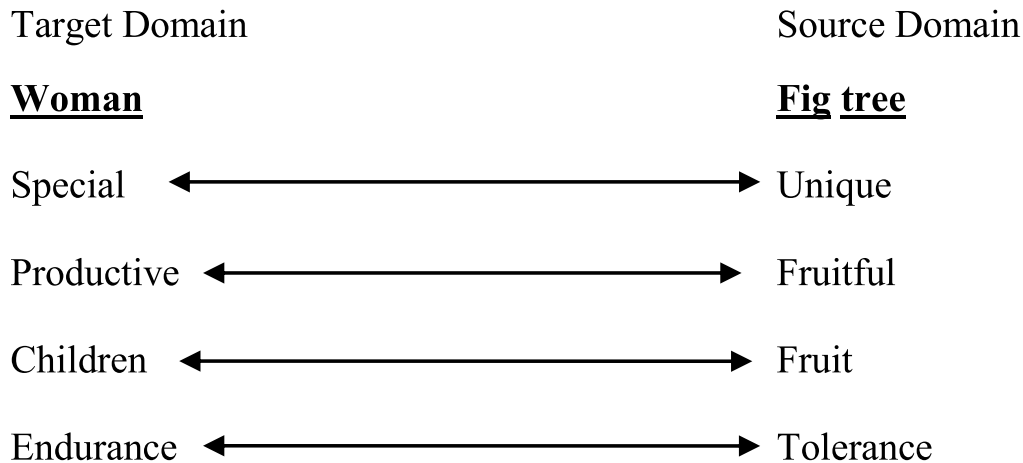

The mapping has demonstrated that woman can be understood in terms of fig tree. As fig is unique among trees for its tender nature, woman is also special for her natural endowment. A fig is a fruitful tree, just as woman is productive. Fig produces sweet fruit while woman also produces good children that make society interesting. Fig can tolerate seasonal drought while woman can endure marital challenges.

Syntactic Representation

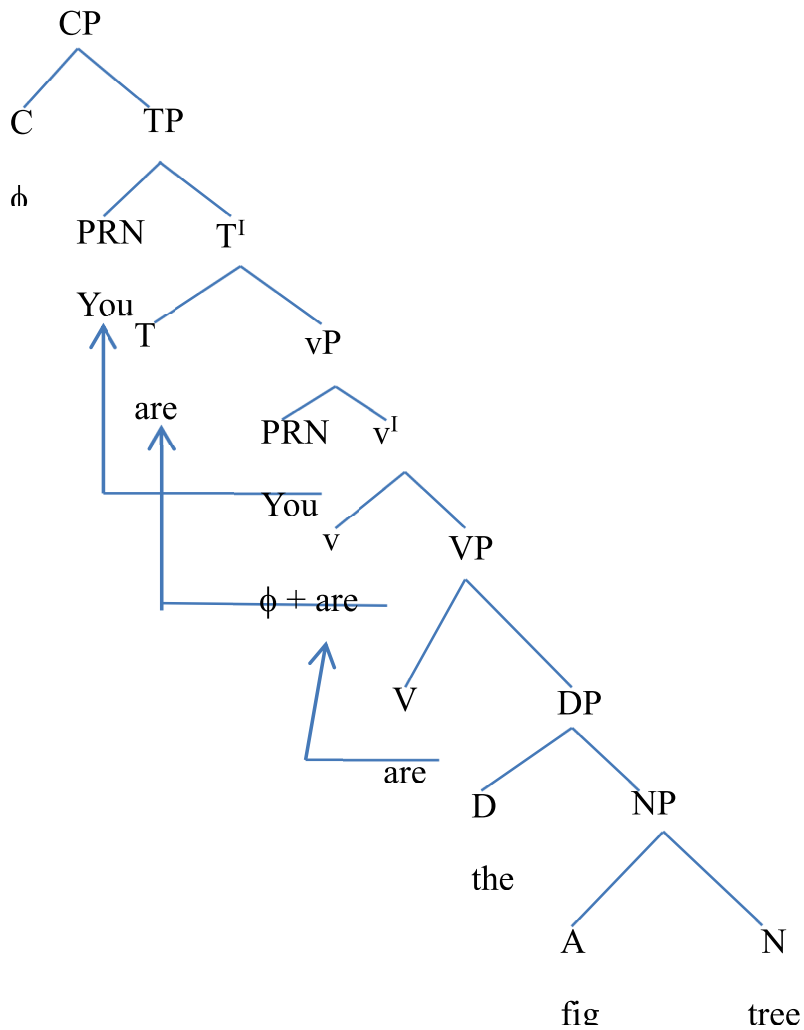

The above conceptual metaphor is slightly different from the previous one, as there is a noun phrase (NP) within the determiner phrase (DP) 'the fig tree'. The auxiliary 'are' was first of all merged under V (Verb) before it was finally moved to T position.

Conceptual Metaphor 5: Obedience is Sacrifice

'Obedience is sacrifice' is a conceptual metaphor. The source conceptual domain is sacrifice while the target conceptual domain is obedience. It implies that obedience is understood in terms of sacrifice. Obedience shares some features that make it comparable to sacrifice. This is demonstrated through conceptual mapping.

Target Domain

Source Domain

Obedience

Sacrifice

Please	←————→	Appease
Higher Authority	←————→	Gods
Demanding	←————→	Cost
Respect	←————→	Gratitude

The mapping has displayed how obedience can be understood in terms of sacrifice. Sacrifice is done to appease to gods or deities in order to obtain their favour while obedience is to please someone or authorities. Sacrifice is given to gods or deities while obedience is done to please higher authorities. Sacrifice has a cost to prepare it while obedience is demanding. Sacrifice may be done to show gratitude to gods while obedience is a mark of respect.

Syntactic Representation

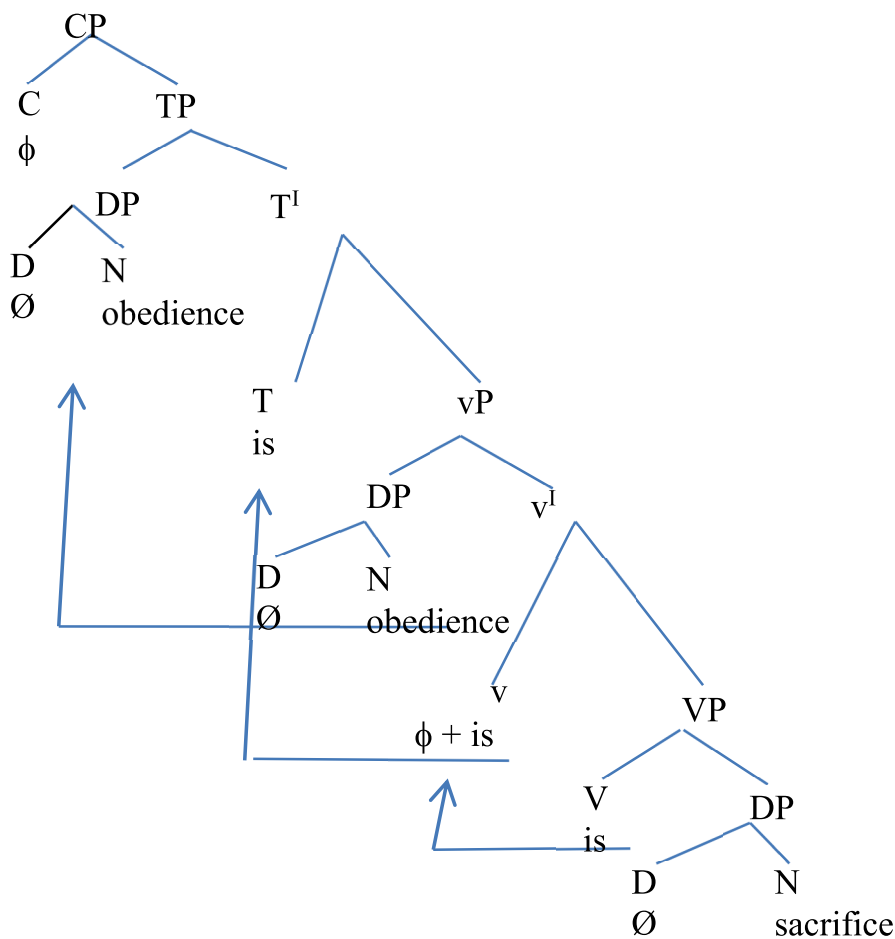

The above conceptual metaphor takes a different form, as the two nouns (both the subject and compliment ‘obedience’ and ‘sacrifice’) are analysed as DPs respectively. This is based on the assumption widely referred to as the DP hypothesis which posits that all nominal and pronominal expressions are DPs (whether there is an overt determiner or null one). Hence, the nouns ‘obedience’ and ‘sacrifice’ were analysed as having null determiners (i.e. projection of a null determiner constituent).

Analysis of conceptual metaphors in *He Goat*

Data presentation

- That woman is evil.
- She is poison.
- You are not a horse.
- Uwape has become black sheep of the family.
- She is an old cargo.

Data Analysis

Conceptual Metaphor 1: That woman is evil

‘That woman is evil’ generates a conceptual metaphor ‘woman is evil’. The source conceptual domain is evil while the target conceptual domain is woman. Woman is understood in terms of evil. The implication of this is that woman and evil share some attributes that make them comparable. The attributes are explored below through mapping.

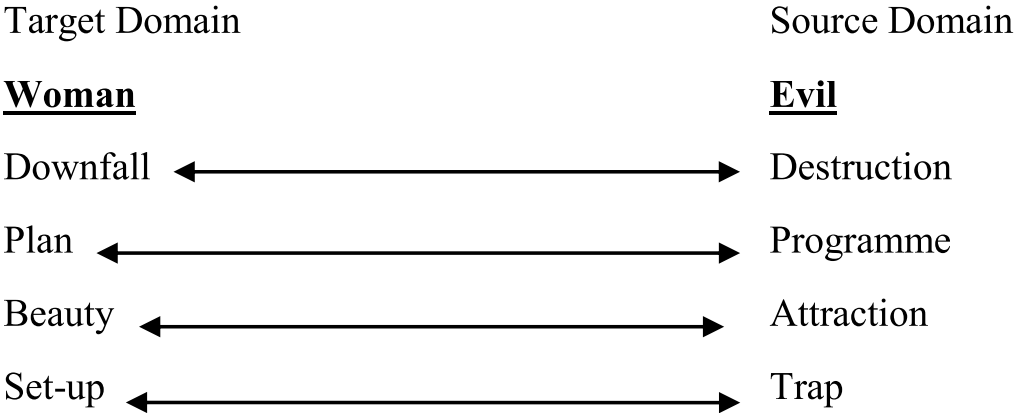

In the exploration of the conceptual metaphor through mapping of the two conceptual domains, the meaning of that woman is evil can be generated through the sets of correspondence in the two conceptual domains. Evil brings destruction to both male and female while woman can be used to cause downfall of both man and woman. Evil can be programmed into someone's life or something: woman can be planned and planted into a man's life. Evil can be attractive as a trap while the beauty of a woman can be used as a set-up.

Syntactic Representation

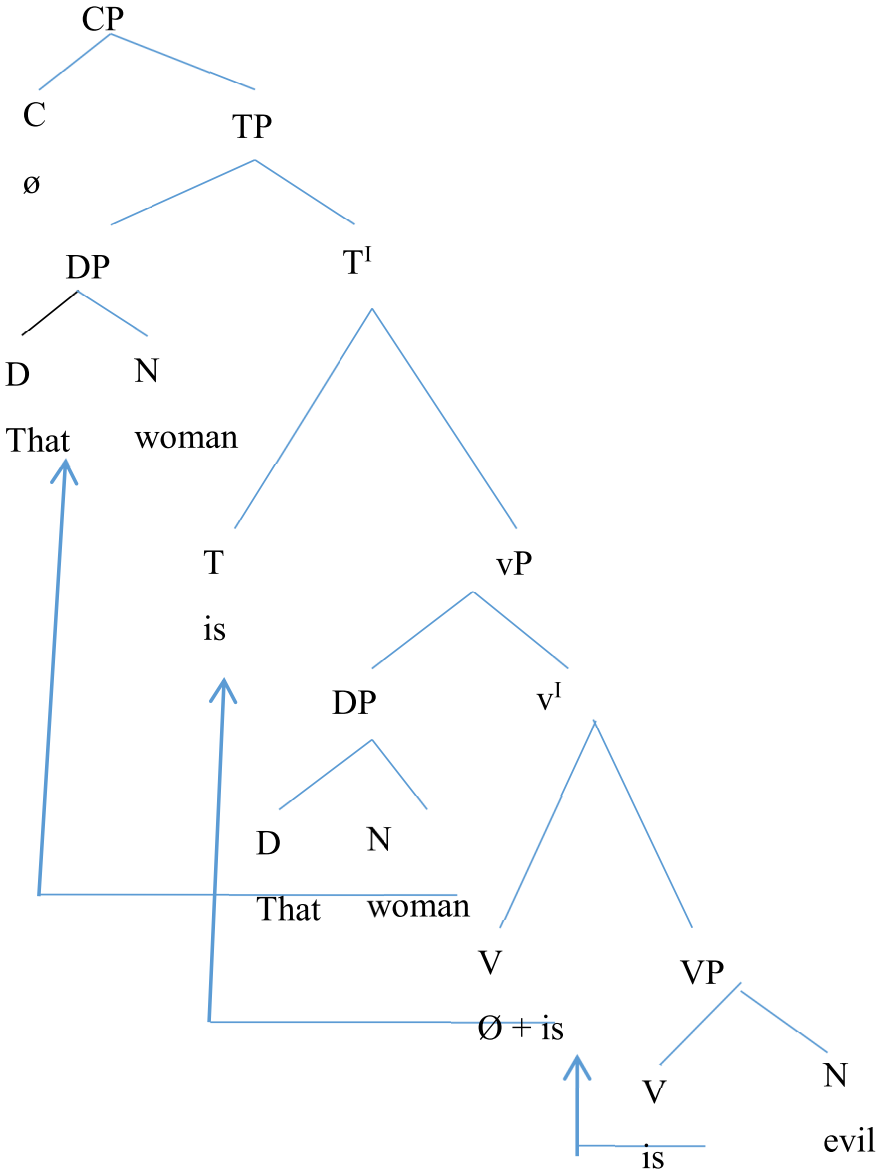

The ‘That’ used in this structure is a determiner and not a complementiser by virtue of its position in the sentence. We can replace ‘that’ with other words of similar word category in a bid to know whether it is a determiner or a complementiser. This indicates that substitution method is the most reliable syntactic test in determining the grammatical class of a word.

Conceptual Metaphor 2: She is poison

‘She is poison’ generates a conceptual metaphor ‘woman is poison’. The source conceptual domain is poison while the target conceptual domain is woman. It shows that woman could be understood in terms of poison because of some attributes shared by the two concepts. The attributes are displayed through mapping.

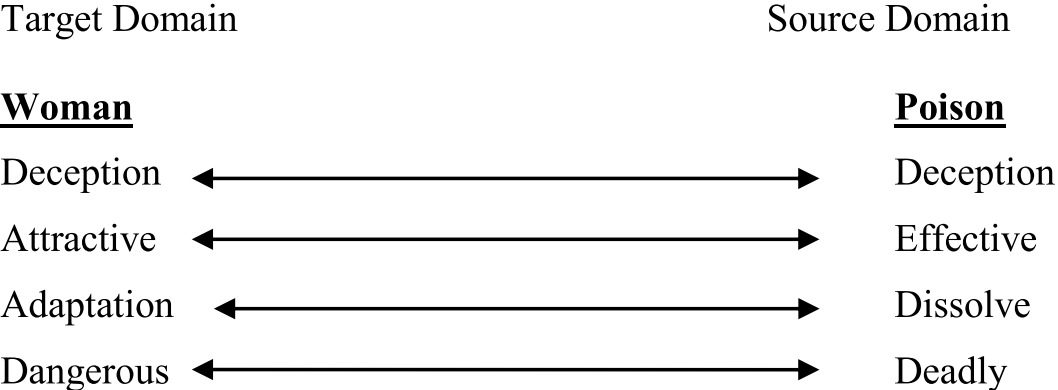

Mapping of the two correspondences in the two conceptual domains demonstrates that woman can be interpreted in terms of poison. Meaning of the metaphor could be generated from the sets of correspondence in the two domains mapped. Poison may be colourless and odourless for deception purpose: woman can also appear innocent and harmless to deceive others. Poison is effective to kill on time while woman, who is beautiful, easily attracts attention. Poison can quickly dissolve in substance while woman could adapt to new home she is married or assigned to. Poison is deadly while woman could be dangerous if she is used as a trap.

Syntactic Representation

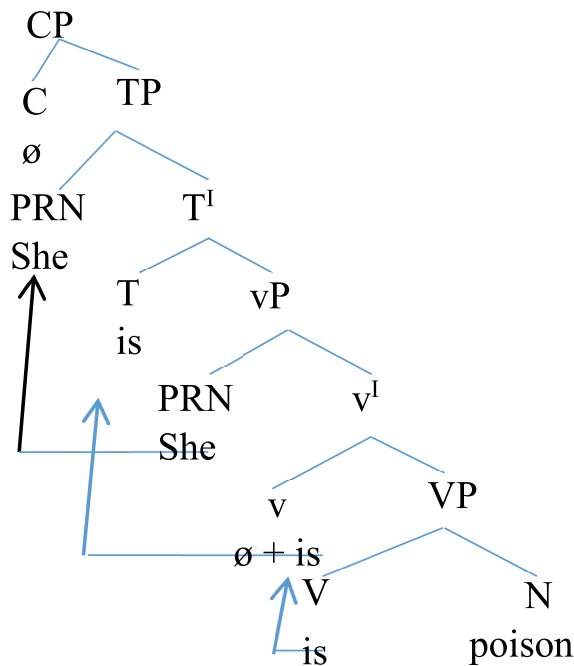

The above metaphor is synonymous with ‘Obedience is sacrifice’. The structure only differs in that ‘She’ is a pronoun (PRN) and poison is directly analysed as a noun (N). The word ‘is’ by virtue of being a tense (T) and the only verbal element in the structure, would be moved from V(Verb) to T(Tense).

Conceptual Metaphor 3: You are not a horse

‘You are not a horse’ generates a conceptual metaphor in a negative form ‘man is not a horse’. Horse is the source conceptual domain while man is the target conceptual domain. The meaning of the metaphor is derived from features shared by the two conceptual domains but not in absolute term, and those not shared by the two conceptual domains. Mapping of these features is demonstrated below.

Target Domain		Source Domain
<u>Man</u>		<u>Horse</u>
Strong	←————→	Stronger
Fast	←————→	Faster
Active	←————→	Hyperactive
Bold	←————→	Daring

The mapping here shows that features shared by the two conceptual domains are in different proportions which portrays that man cannot be fully understood in terms of horse. Man is strong but not as strong as horse. Man could run fast but not as fast as horse. Man may be active but not as active as horse. Man may be bold to confront challenges, but horse is confident enough to dare war without fear of death. The meaning of ‘you are not a horse could be successfully generated from the mapped features.

Syntactic Representation

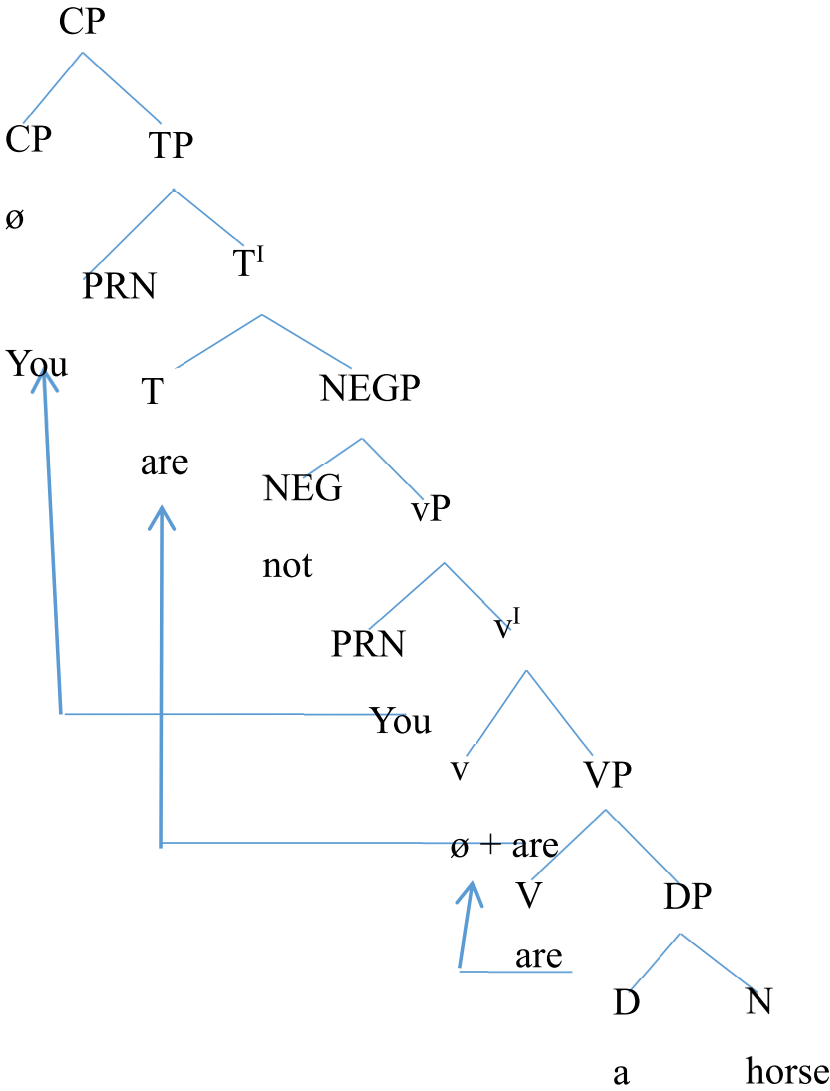

The above conceptual metaphor is slightly different, as it contains a negative particle ‘not’ which has to be accounted for on the tree diagram. Hence, our T node selects a NEGP (Negation Phrase) instead of the usual light verb phrase (vP). The negative item ‘not’ is positioned under NEG which is the head constituent of the NEGP.

Conceptual Metaphor 4: Uwape has become black sheep of the family

‘Uwape has become black sheep of the family’ generates ‘Uwape has become a sheep’ which generates ‘man has become sheep’. Sheep is the source conceptual domain while man is the source domain. We are proving here that man can be understood in terms of sheep because of some features that can be found in the two conceptual domains, which is demonstrated through mapping.

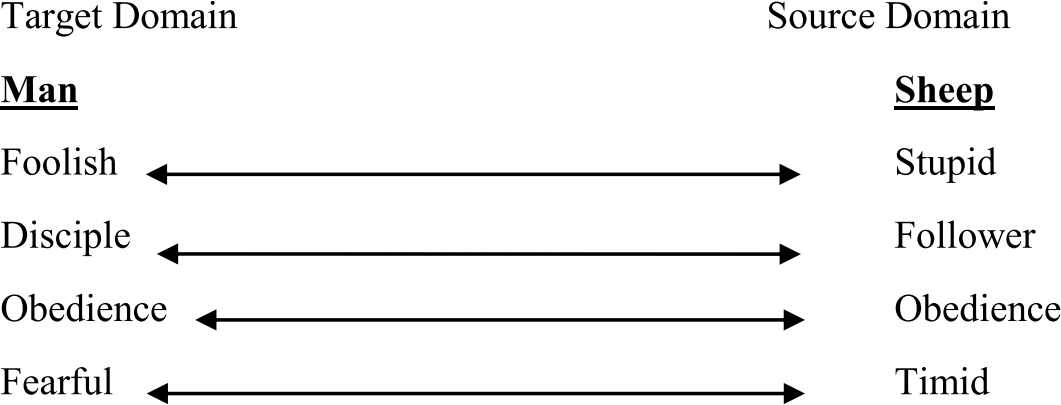

The mapping shows that man and sheep share some features which make it possible to understand man in terms of sheep. Sheep acts stupidly while man can act foolishly. Sheep follows the leading sheep or shepherd blindly while man can also be a faithful disciple of a leader. Sheep is obedient to the shepherd while man could also be obedient to the authority above him. Sheep is timid while man could be fearful. These features help to generate the meaning of the metaphor.

Syntactic Representation

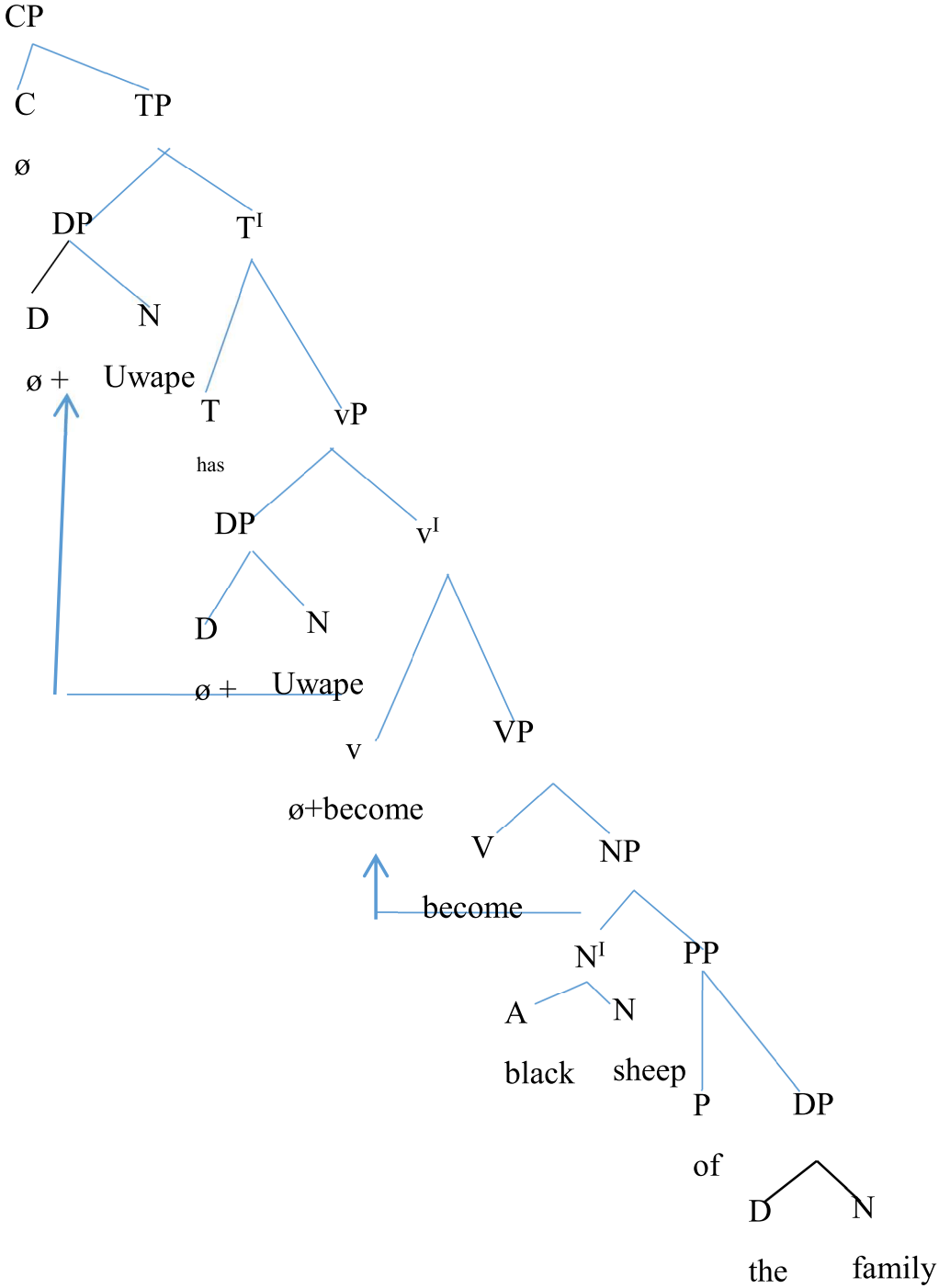

The above conceptual metaphor has both a T(Tense) and a V(Verb). The NP(Noun Phrase) complement of the Verb ‘become’ is a complex one; thus, the need to introduce an N¹(N bar) to be able to properly represent all the nodes.

Conceptual Metaphor 5: She is an old cargo

‘She is an old cargo’ generates a conceptual metaphor ‘woman is a cargo’. The source conceptual domain is cargo while the target conceptual domain is woman. The metaphor implies that woman can be understood in terms of cargo. This is so as a result of features shared by the concepts in the two domains.

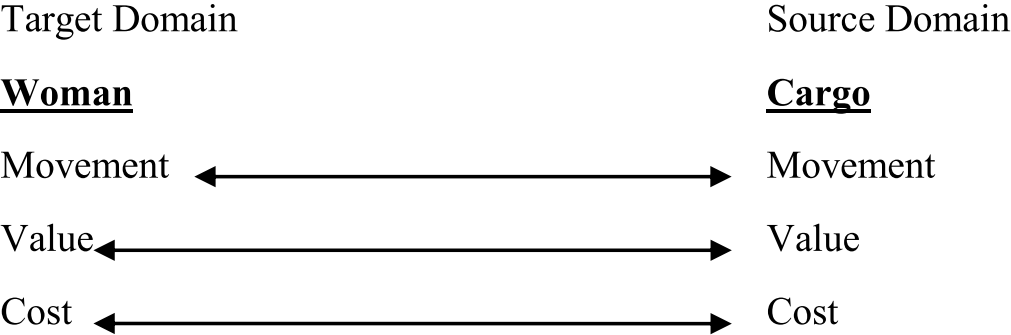

The mapping has shown that the two conceptual domains are related in some areas. Woman could be interpreted in terms of cargo as a result of some features shared by two concepts in the metaphor. Both cargo and woman engage in movement. Cargo is carried from one place to another while woman is married from one family to another. Both of them have value: cargo is valued in size and content while woman is valued in beauty and character. Cost of transport is incurred in movement of cargo while getting married to a woman or taking a woman out on a date attracts more than financial cost.

Syntactic Representation

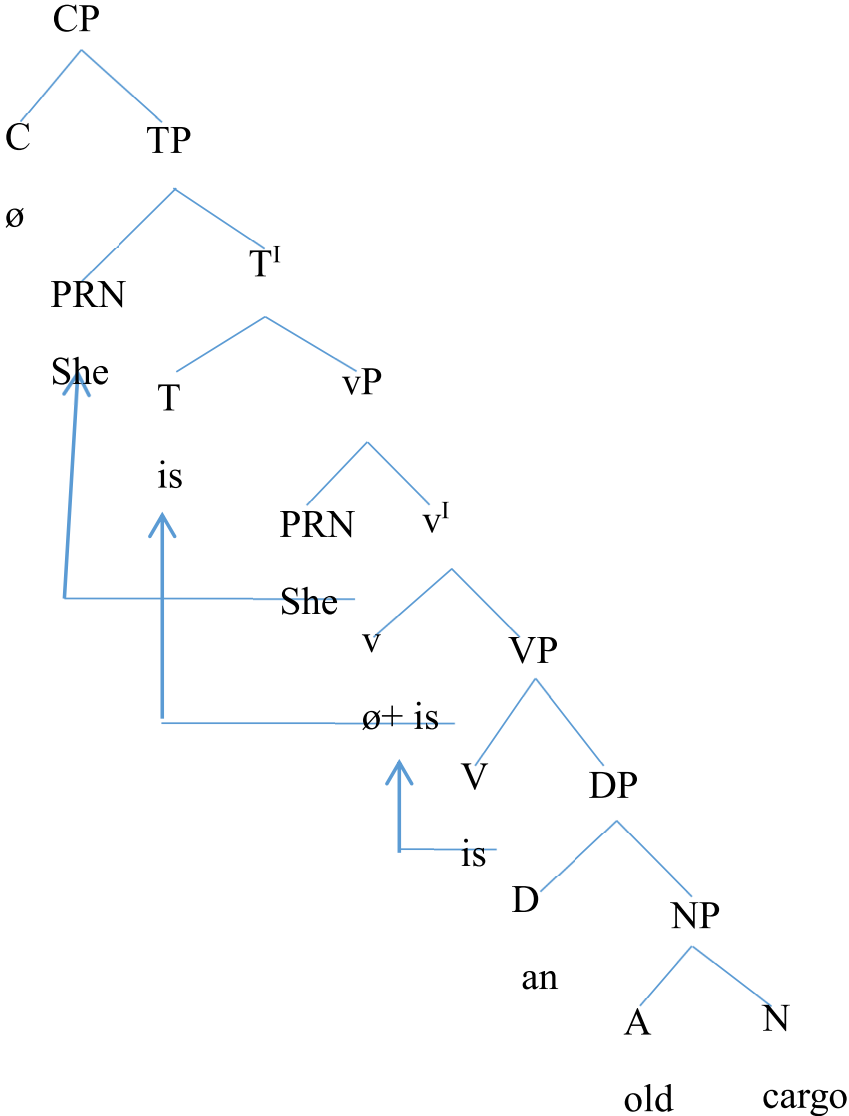

The structure of the above conceptual metaphor is similar to conceptual metaphor 4 ‘You are the fig tree’. Hence, the tree diagrams are identical.

Discussion

As earlier stated, the major preoccupation of this work is to determine if the meaning of conceptual Metaphors indeed affects the syntactic structures. The study has shown that conceptual metaphor has syntactic pattern similar to canonical sentences; that is, it would be analysed in like manner a normal sentence would be syntactically represented on

the tree diagram. It has also revealed that the syntactic structure of conceptual metaphor has nothing to do with its interpretation. The structural pattern of each of the metaphors analysed does not influence their interpretation. Also, it is evident from the analyses that some of the conceptual metaphors are structurally similar in terms of their arrangement and analyses on the tree diagram. In some few instances as in conceptual metaphor 1 and 2 “You are a dog” and “I am a Leopard”, the grammatical categories of the two metaphors are synonymous although the words selected are different. This indicates that in some instances, there could be similarity in the tree structures. In addition, the analysis of conceptual metaphor 1 in the movie *He Goat* validates that substitution method is the best syntactic method in determining the grammatical category of a word; as seen in the case of ‘that’ which was analysed as a determiner and not a complementizer in the sentence “That woman is evil”. We also observed from the analyses that the introductions of new bar levels are essential in order to properly represent the nodes. For example, conceptual metaphor 3 “You are not a horse” in the movie *He Goat* has the negative particle ‘not’ , hence there must be an introduction of the Negation Phrase to be able to effectively represent ‘not’ on the tree diagram. The negative item ‘not’ is positioned under NEG which is the head constituent of the NEGP.

Furthermore, this study reveals various elements that are combined to form conceptual metaphor and technicalities such as movement and merger operators involved in its syntactic representation. It finally shows that conceptual metaphors are interpreted through mapping of the sets of correspondence shared by the concepts in the two conceptual domains and those that are shared not in absolute term in case of metaphors in negative form.

Conclusion

From the analysis above, it is evident that conceptual metaphors can also be represented syntactically on tree diagrams without obstructing their meanings. Conceptual metaphors can also be analysed in the same way with canonical (i.e. normal) sentences. From the tree analyses above, it is obvious that a simple sentence can also be ridden with several technicalities as in the case of movement and merger operations.

References

- Ademola-Adeoye, Feyisayo (2012). 'Raising the Minimalist Programme (MP)' *Lagos Review of English Studies*. Vol. 17. No. 1
- Adesanya, Afolabi. (1997). 'From Film to Video.' In Haynes, Jonathan (ed.) *Nigerian Video Films*. Ibadan: Kraft Books Limited.
- Bailer-Jones, D. M. (2002). 'Models, Metaphors and Analogies.' In Machamer, Peter and Silberstein, Michael (Eds.) *The Blackwell Guide to the Philosophy of Science*. Oxford: Blackwell Publishers.
- Bielenia-Grajewska, Magdalena. (2009). 'The Role of Metaphor in the Language of Investment Banking.' *IBÉRICA*. 17. 139-156.
- Broekhuis, H., & Woolford, E. (2010, December 9). *Minimalism and Optimality Theory*. Retrieved October 30, 2015, from <http://www.google.com.ng/people.umass.edu/ellenw/minimalismandoptimalitytheory>
- Chomsky, N. (1993). 'A Minimalist Program For Linguistic Theory' In Hale and Keyser (eds.). pp.1-52
- Chomsky, N. (1982). *Some Concepts and Consequences of the Theory of Government and Binding*. Cambridge, Mass.: MIT Press.
- Cunningham-Parmeter, Keith. (2011). 'Alien Language: Immigration Metaphors and the Jurisprudence of Otherness.' *Fordham Law Review*. Vol. 79, 1546-1597.
- Dadzie, A. B. K. (2004). 'Some Syntactic Characteristic of Nigerian English.' In Dadzie, A. B. K. and Awonusi, Segun (Eds.) *Nigerian English Influences and Characteristics*. Lagos: Concept Publications.
- Fromkin, Victoria, Rodman, Robert and Hyams, Nina. (2003). *An Introduction to Language*. 7th Ed. Australia: Thomson Wadsworth.
- Igbeneghu, Boniface O. (2003). 'The Determiner Phrase in Etsako: A Minimalist Approach.' *Lagos Notes and Records*. Vol. IX.
- Kövecses, Zoltán. (2002/2010). *Metaphor: A Practical Introduction*. (2nd Edition). USA: Oxford University Press.
- Haynes, Jonathan. (2005). 'Nollywood: What's in a Name.' *Guardian Newspaper*. Nigeria, July 3.

- Haynes, Jonathan and Okome, Onookome. (1997). 'Evolving Popular Media: Nigerian Video.' In Haynes, Jonathan (ed.) *Nigerian Video Films*. Ibadan: Kraft Books Limited.
- Lakoff, G. (1989). 'Philosophical Speculation and Cognitive Science.' *Philosophical Psychology*. 2. 1.
- Lakoff, G. (1990). 'The Invariance Hypothesis: Is Abstract Reason Based on Image-Schemas?' *Cognitive Linguistics*. 1, 39-74.
- Lakoff, George and Johnson, Mark. (1980). 'Conceptual Metaphor in Everyday Language.' *The Journal of Philosophy*. Vol. 77. 8, 453-486.
- Lakoff, George and Johnson, Mark. (2003) *Metaphors we live by*. London: University of Chicago Press.
- Mcglone, Matthew S. (1996). 'Conceptual Metaphors and Figurative Language Interpretation: Food for Thought?' *Journal of Memory and Language*. 35. 544-565
- Oni, Duro. (2008). 'Context and Nature of Contemporary Nigerian (Nollywood) Film Industry.' In Ogunleye, Foluke (Ed.) *Africa through the Eye of the Camera*. Swaziland: Academic Publishers.
- Opeibi, B. O. (2009). *Discourse, Politics and the 1993 Presidential Election Campaigns in Nigeria*. Ibadan: Straight Gate Publishers Limited.
- Papagno, Costanza. (2001). 'Comprehension of Metaphors and Idioms in Patients with Alzheimer's Disease: A Longitudinal Study.' *Brain*. 124,1450-1460.
- Pierson, Cheri. (2008). 'Theory-to-Practice Reflections on Educational Metaphors For Teaching English as a Second Language to Adult Learners.' *PAACE Journal of Lifelong Learning*. Vol. 17, 51-61.
- Radford, A. (2004). *Minimalist Syntax: Exploring the Structure of English*. Cambridge: Cambridge University Press.
- Radford, A. (2009). *Analysing English Sentences: A Minimalist Approach*. Cambridge: Cambridge University Press.

Abbreviations And Symbols

CP	=	Complementizer Phrase
C	=	Complementizer
TP	=	Tense Phrase
T^I	=	Teebar
T	=	Tense
vP	=	Light Verb Phrase
v	=	Light Verb
VP	=	Verb Phrase
V	=	Main Verb
PRN	=	Pronoun
Ø	=	Null Marker
D	=	Determiner
DP	=	Determiner Phrase
N	=	Noun
NP	=	Noun Phrase
NEGP	=	Negation Phrase
NEG	=	Negation
PP	=	Prepositional Phrase
P	=	Preposition